



The Productivity Devices Company



Installation Clamping Modules

Pneumatic, Single Acting

MPL5703

OPERATING & INSTALLATION MANUAL

Keep for future use!

Document number: MPL5703

Revision: A

Revision Date: 9/23/25

ECN: 5818

For the following part numbers:

- 570258 - ZERO POINT, KP10.3, 25KN, PNEU OPEN, PNEU BLOW OFF, SA
- 570259 - ZERO POINT, KP20.3, 55KN, PNEU OPEN, PNEU BLOW OFF, SA

© 2025 by Vekttek LLC

This operating & installation manual and all illustrations contained therein are protected by copyright. Every use without prior written consent of the publisher that is outside the limits authorised under copyright is prohibited and punishable. That applies especially for reproductions, translations, microfilming, storage, and processing in electronic systems. For approval inquiries, please contact the publisher.

I. Contents

1	Introduction	5
2	Safety	6
3	Description of the installation clamping modules	9
3.1	Technical data sheet	9
3.2	Use of installation clamping module	11
3.3	Design of installation clamping modules	12
3.3.1	Circuit diagram of pneumatic installation clamping modules	13
3.3.2	Dimensions of installation clamping modules	13
3.3.3	Example for circuit diagram of installation clamping modules	14
3.4	Pull-stud	14
3.4.1	Design	14
3.4.2	Installation Instructions	15
3.4.3	Arrangement and tolerances of the pull-studs	15
3.4.4	Arrangement of the pull-studs - classical	16
3.4.5	Arrangement of the pull-studs - optional	16
3.5	Performance and restrictions on use	17
3.5.1	Pull-in force and locking force	17
3.5.2	Holding force	17
3.5.3	Safety precautions	17
3.6	Function description	18
3.6.1	Function of the pneumatic installation clamping module	18
3.6.2	Support control	18
3.7	Necessary tools	18
4	Transport and Storage	19
4.1	Inspection by recipient when taking possession	19
4.1.1	Unpacking	19
4.2	Supplied as standard	20
4.3	Intermediate storage	20
5	Installation	20
5.1	Ambient and Operating Conditions	21
5.2	Preparatory measures	21
5.3	Install the installation clamping modules	22
5.4	Disassemble installation clamping modules	24
6	Commissioning	26
7	Operation	27
7.1	Opening procedure	27
7.2	Clamping process	27
7.3	Integrated blow-out procedure	27
7.4	Manual blow-out process	27
7.5	Clamp installation clamping modules	28
8	Fault and repair measures	28
9	Maintenance	29
9.1	Safety measures for maintenance work	29
9.2	Inspection and maintenance work	30
9.2.1	Maintenance intervals	30

9.2.2 Preparatory measures	30
9.2.3 Maintenance – daily.....	30
9.2.4 Maintenance – monthly.....	31
9.2.5 Maintenance – annual	31

1 Introduction

The Operating & Installation Manual provides the information necessary for the safe and reliable operation of the installation clamping modules. All personnel involved in installation, operation, maintenance, cleaning, or troubleshooting must read and follow this manual. All safety instructions and procedures must be strictly observed. Anyone working with this equipment must understand and comply with these instructions.

After reviewing the Operating & Installation Manual, users will be able to:

- Properly install and safely operate the installation clamping modules
- Disassemble the clamping modules as required
- Clean the clamping modules as specified
- Respond appropriately to faults or malfunctions

In addition to this manual, all applicable federal, state, and local regulations — including workplace safety and environmental requirements — must be followed.

Vektek LLC reserves the right to revise this documentation at any time to reflect product improvements or design updates without obligation to issue an immediate revision.

Warranty and Liability

All information in this Operating & Installation Manual has been prepared in accordance with applicable standards, current industry practices, and Vektek LLC's technical expertise. This manual does not replace the user's responsibility to determine whether the installation clamping modules are suitable for a specific application. The manufacturer or distributor must conduct a complete risk assessment, evaluation, and functional test to confirm suitability for the intended use.

Warranty and liability claims are excluded for personal injury or property damage resulting from:

- Improper or unintended use of the installation clamping modules
- Incorrect installation, startup, operation, maintenance, or cleaning
- Failure to follow the instructions and safety information in this manual
- Use of unqualified or untrained personnel
- Modifications made without prior written approval from Vektek LLC
- Improper or unauthorized repairs
- Use of non-approved replacement parts or components that do not meet required specifications
- External factors such as accidents, environmental conditions, or force majeure

Service / customer service



Our customer service is available to you for technical information:

Phone: +1(800)992-0236

Request Customer Support

Email: CustomerSupport@Vektek.com

In addition, our employees are constantly interested in new information and experiences resulting from use of the product that could be valuable for improving our products.



WARNING

Failure to observe the following safety notes can have serious consequences:

Endangering of people by mechanical and chemical influences and the failure of important product functions!

Thoroughly read through the safety and danger notes in this section before you put the installation clamping modules into operation.

In addition to the notes in this operating & installation manual, observe the general safety and accident-prevention regulations.

In addition to the notes in this operating & installation manual, observe the existing national occupational, operating and safety regulations. Also comply with existing internal company regulations.

Intended use

Safe operation of the installation clamping modules is ensured only when they are used as intended. These are spring-actuated, single-acting clamping devices designed to hold an interchangeable pallet or workpiece in a pressure-free, self-locking condition using a Vektek LLC pull stud.

The modules are intended exclusively for positioning and clamping interchangeable pallets or workpieces used in cutting or non-cutting machining applications on machine tools or other suitable industrial equipment. They must only be operated within their specified technical limits. Maximum load capacities and operating pressure must never be exceeded. Any other use requires prior approval from the manufacturer.

Only pallets or workpieces equipped with an approved flat-head screw and pull stud may be clamped. The modules are designed for hydraulic and/or pneumatic operation and are intended strictly for industrial applications.

Use outside the intended purpose is prohibited. The following are specifically not permitted:

- Using the installation clamping modules as lifting devices
- Using the modules as pulling elements
- Using defective, unsuitable, or unapproved accessories
- Creating installation layouts that do not comply with Vektek LLC specifications
- Operating the modules while untrained personnel are within the hazard area
- Operating the modules if they are damaged, malfunctioning, or modified
- Operating the modules without proper training

Intended use also includes:

- Following all instructions in the Operating & Installation Manual
- Performing inspections and maintenance at required intervals
- Operating within all specified conditions

NOTE

Notes on fastening bolts and pull-studs:

The holding force of the installation clamping modules is limited by the strength of the screw connection between the pull-stud and the fixture. Only screws with the permitted strength class may be used. Only original Vektek LLC pull-studs may be used. If the pull-stud is used in the company's own fixtures, an adequately dimensioned threaded bore and sufficient mounting material strength must be planned for by the owner.

All technical specifications listed in the technical data must be strictly observed.

Structural changes to the installation clamping modules

No modifications, additions, or alterations may be made to the installation clamping modules without prior written approval from Vektek LLC.

Unauthorized modifications void the manufacturer's warranty.

Replace any damaged or worn components immediately. Use only original replacement, wear, and accessory parts supplied or approved by Vektek LLC. These components are specifically designed for safe operation. Use of third-party parts may compromise safety and load capacity. Parts or accessories not supplied by Vektek LLC are not approved for use.

Foreseeable improper use

Any use beyond the intended application can result in severe injury.

Examples of foreseeable misuse include:

- Operating the modules beyond the limits specified in the technical data
- Using the modules as tool holders, lifting devices, hoists, or press tools
- Using the modules in unsuitable or prohibited work environments

General safety notes

- The installation clamping modules may only be operated and maintained by personnel who have read and understood this manual.
- Use the installation clamping modules only as intended.
- Do not perform any actions that compromise personnel safety or equipment integrity.
- Keep the work area clean and organized to prevent hazards caused by debris or loose parts.
- Do not exceed rated performance specifications.
- Ensure all labels and markings on the modules remain legible and replace them if necessary.

- Installation and service work may only be performed by qualified or properly instructed personnel.
- In the event of a malfunction, stop operation immediately. Repairs must be performed by trained personnel or Vektek LLC.

Keep this Operating & Installation Manual at the equipment location and ensure it is accessible to all personnel working with the modules.

Special dangers / residual risks

Risk of injury if the fixture or workpiece falls



WARNING

Risk of injury if the fixture or workpiece falls due to opening of the installation clamping module!

Non-observance can result in death or serious injuries!

Please note that opening of the installation clamping module during operation must be prevented by suitable countermeasures (disconnection of the energy supply after interlocking, use of safety valves or switches).

While working, always wear the protective equipment necessary for the respective work.



WARNING

Risk of injury during overhead applications or horizontal position of the pull-stud axis if the workpiece or fixture falls!

Non-observance can result in death or serious injuries!

In the case of overhead or horizontal applications, please note that the fixture or workpiece must be secured against falling before opening the installation clamping module.

Dangers caused by independent movement of parts



WARNING

The installation clamping modules clamp by means of spring force. There is a risk of injury caused by independent movement of parts into their end positions after emergency off is actuated, after shutdown or if the energy supply fails!

Non-observance can result in death or serious injuries!

Do not reach into the installation clamping modules.

Wait until the system is at a complete standstill.

Use pressure maintenance valves.

3 Description of the installation clamping modules

All illustrations in this document are meant to provide a basic understanding and can deviate from the actual version.

3.1 Technical data sheet

	Unit	KP 5.3	KP 10.3	KP 20.3
Pull-in force and locking force in the system up to	[kN]	1.3	10	17
Holding force in static application	[kN]	13	25	55
Holding force in dynamic application	[kN]	10	15	25
Min. opening operating pressure.	[bar]	5	5	4.5
Max. opening operating pressure.	[bar]	12	12	12
Blow-out operating pressure	[bar]	1 - 6	1 - 6	1 - 6
Opening volume	[cm ³]	6	17	37
Pre-positioning	[mm]	4.0	6.5	12
Repetition accuracy	[mm]	< 0.005	< 0.005	< 0.005
Max. permissible lateral forces	[kN]	5	10	20

	Unit	KP 5.3	KP 10.3	KP 20.3
Max. operating temperature	[°C]	+ 80	+80	+80
Diameter Ø	[mm]	78	112	138
Height	[mm]	30	35	49
Weight	[g]	450	1400	3400
Permissible ambient temperature in operation	[°C]	+ 15 to + 80	+ 15 to + 80	+ 15 to + 80
Permissible ambient temperature during storage	[°C]	+ 10 to + 35	+ 10 to + 35	+ 10 to + 35
Permissible air humidity during storage	[%]	10 to 90	10 to 90	10 to 90
Max. moment of torsion for indexing	[Nm]	-	350	400

NOTE

The holding forces are dependent on the load cycles, i.e. how often the installation clamping modules are subjected to tensile stresses in the axial direction.

1) The application is deemed static if the system is subjected to a max. of 100,000 load cycles at full utilisation of the specified holding force.

2) The application is deemed dynamic if the system is subjected to more than 100,000 load cycles at full utilisation of the specified holding force.

NOTE

Note on the compressed air of the installation clamping modules:

- Prepared with service unit, (dry air, water separator filter, oil-mist lubricator).
- Air purity: Compressed air according to ISO 8573-1: 2010 [7: 4: 4].
- Use only oils of viscosity class VG 32 according to ISO 3448.



WARNING

Risk of injury caused by non-compliance with specified technical data!

Non-observance of the notes can result in damage, malfunctions or total breakdown of the installation clamping modules and impair their safety!

- It must be ensured, by means of a pressure-limiting valve, for example, that the maximum operating pressure is not exceeded. The safety factor is not included in the holding force value. It must be considered individually, depending on the application concerned.
- Pay attention to the max. operational force of the engagement screws (see “3.4.2 Installation Instructions”).
- The lateral force refers to zero point and sword pin. The undersized pin must not be considered for the lateral forces.

3.2 Use of installation clamping module

- Installation clamping modules for automation solutions for set-up-time-optimised clamping with cutting and non-cutting machining.
- The pull-studs are fastened and installed through an engagement screw.
- Support control via the blow-out function: Dynamic pressure with supported interchangeable pallet.
- The installation clamping module is opened pneumatically and locked mechanically by spring force.
- Then the pressure line can be disconnected at any time (installation clamping modules are clamped without pressure).

3.3 Design of installation clamping modules

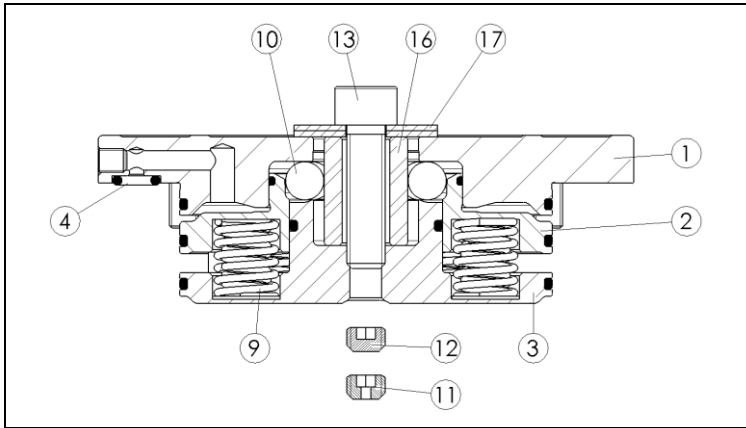

Illustration 1: Pneumatic installation clamping modules

- | | | | |
|----|--------------------|----|----------------------------|
| 1 | Cover | 11 | Threaded stud for blow-out |
| 2 | Piston | 12 | Threaded stud |
| 3 | Floor | 13 | Cylinder screw |
| 4 | O-ring | 16 | Installation sleeve |
| 9 | Compression spring | 17 | Disc |
| 10 | Ball | | |

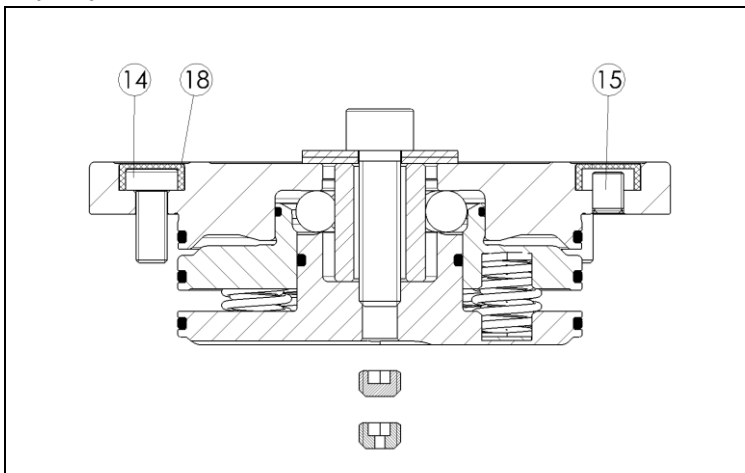



Illustration 2: Pneumatic installation clamping modules. Alternate view.

- | | | | |
|---|--|----|---------------|
| 14 | Cylinder screw | 15 | Threaded stud |
| 18 | Cover cap | | |
|  | Pre-installed installation aid, consisting of items 13,16, & 17. | | |

3.3.1 Circuit diagram of pneumatic installation clamping modules

The installation clamping modules have two pneumatic connections.

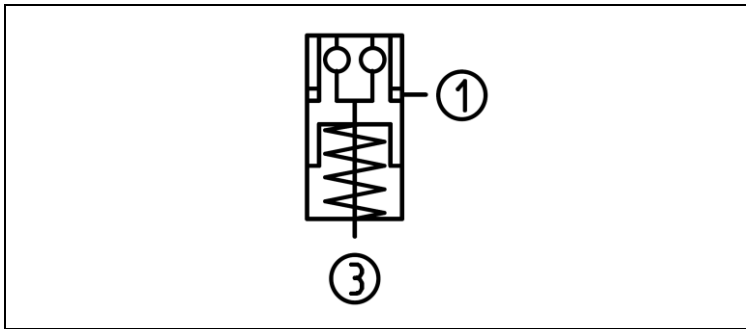

Illustration 3: Circuit diagram of installation clamping modules

- 1 Pneumatic opening
- 3 Pneumatic blow-out

3.3.2 Dimensions of installation clamping modules

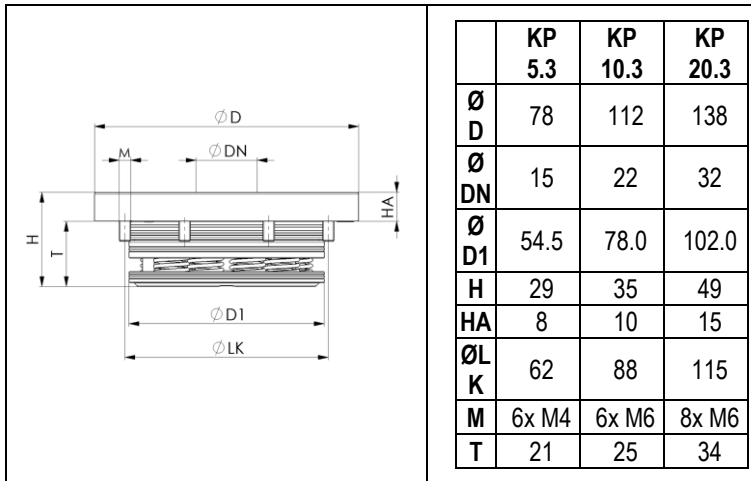

Illustration 4: Dimensions of installation clamping modules

3.3.3 Example for circuit diagram of installation clamping modules

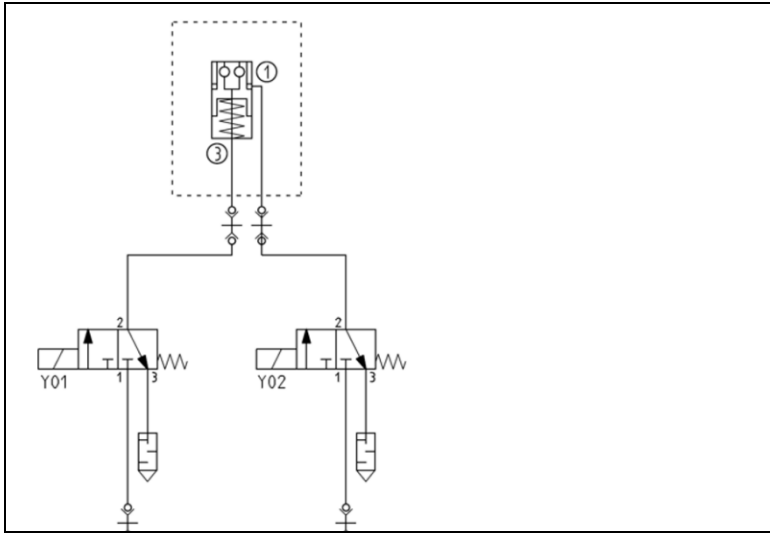

Illustration 5: Example for circuit diagram of installation clamping modules

3.4 Pull-stud

3.4.1 Design

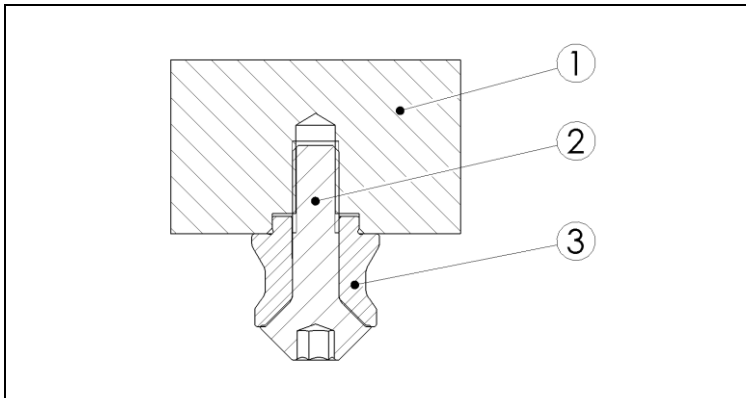

Illustration 6: design of pull-stud

- 1 Interchangeable pallet
- 2 Engagement screw
- 3 Pull-stud

3.4.2 Installation Instructions

- Bring the pull-stud with the engagement screw into the intended hole of the pallet. While doing so, observe the arrangement of the various screw shapes and the alignment of the sword pin with the clamping system.
- Tighten the engagement screw with a torque wrench and to the defined torque.



Size	Thread [mm]	Retaining force [kN]	Torque [Nm]
K5.3	M6	8.5	16
K5.3	M8	13	28
K10.3	M8	17	34
K10.3	M10	25	60
K20.3	M10	25	60
K20.3	M12	43	120
K20.3	M16	55	215

3.4.3 Arrangement and tolerances of the pull-studs

Note: The timing “points” of the timing pull-stud must be at an angle of 90° to the connecting axle between this and the zero-point stud.

Distance tolerance:

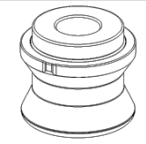
- A = Zero-point to Timing Pull Stud pin: +/- 0.01 mm
- B = Zero-point/ Timing Pull Stud to undersized pin: +/- 0.03 mm

Designs of the pull-studs	Description
	Zero-point pull-stud (1) - for full centring
	Timing pull-stud (2) - for centring the axis that is still free
	Undersize pull-stud (3) - holding and clamping function only

3.4.4 Arrangement of the pull-studs - classical

This arrangement of the pull-studs always optimally positions the interchangeable pallet. At the same time, the zero-point pull-stud always represents the reference point. The Timing pull-stud serves to compensate for the free axis. The undersize pull-stud has only a clamping and holding function.

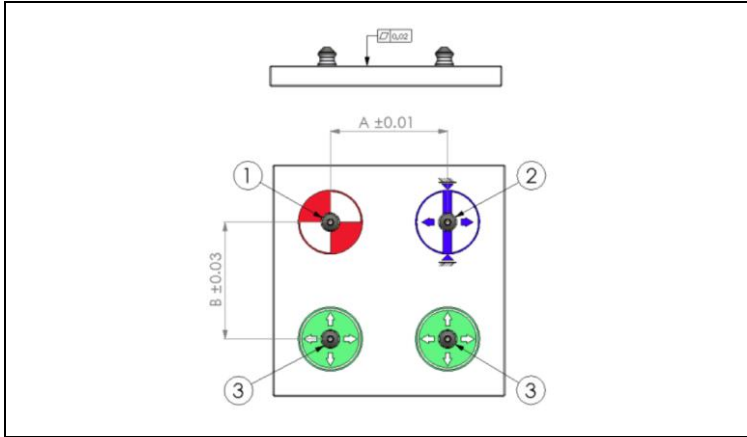

Illustration 7: Arrangement and tolerances of the pull-studs - classical

- 1 Zero-point pull-stud
- 2 Timing pull-stud
- 3 Undersize pull-stud

3.4.5 Arrangement of the pull-studs - optional

This exclusive use of timing pull-studs compensates for stronger temperature influences. The reference point always remains in the centre of the pallet. Of course, temperature influences from machine processing can generally be ignored since the heat generated is conducted away by the chips and coolant.

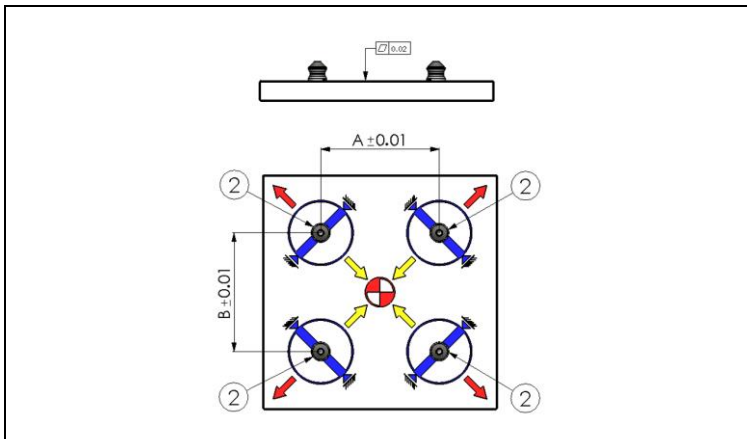

Illustration 8: Arrangement and tolerances of the pull-studs - optional

- 2 Timing pull-stud

3.5 Performance and restrictions on use

3.5.1 Pull-in force and locking force

The pull-in and locking force describes the force with which the bolt is pulled in and clamped with positive interlocking in the clamping module.

3.5.2 Holding force

The holding force specifies the maximum permissible axial pulling force of the engagement bolt screw. A safety value suitable for the application must additionally be taken into consideration.

Elevated tensile forces can cause a material-induced elastic deformation of the components.

3.5.3 Safety precautions

Safety catch:



WARNING

Dangers caused by vertically and horizontally suspended clamping!

Non-observance can result in death or serious injuries!

- Attach an additional mechanical safety catch for vertically and horizontally suspended clamping.
- Consider a hazard analysis of the forces occurring and then carry out an accident risk assessment to take appropriate protective measures.

Rotary applications:



WARNING

Dangers caused by rotary applications!

Non-observance can result in death or serious injuries!

- For rotary clamping, please note that contact monitoring (opening and locking control) and support control are mandatory for safety reasons.
- Consider a hazard analysis of the shearing, centrifugal and unbalanced forces occurring and then carry out an accident risk assessment to take appropriate protective measures.

3.6 Function description

3.6.1 Function of the pneumatic installation clamping module

The installation clamping module has three pneumatic connections. The installation clamping module is pneumatically opened (connection 1) and through spring force and mechanically locked through post-clamping force. The blow-out (connection 3) is used for cleaning the inside and the contact surface. Shavings or dirt can be removed through the integrated blow-out.

3.6.2 Support control

Support control takes place via the blow-out (3). Dynamic pressure arises, which can be sensed through a dynamic pressure control. The support control may only take place when the blow-out is switched off.

NOTE

Monitoring of the pneumatic sensing functions is performed using a **Vekttek Air Sensing Control Kit (ASCK), model 50-8240-00**. The ASCK supplies regulated compressed air to the sensing channels and monitors system back-pressure using an integrated electronic pressure switch.

Pressure changes occur when airflow conditions vary, for example when a workpiece is seated on the clamping module (support control) or when the piston is in the open or closed position (opening and locking control).

When airflow is restricted, system pressure rises above a defined setpoint, and a confirmation signal is generated. When airflow is unrestricted, pressure falls below the reset threshold and the signal is removed.

The ASCK provides reliable pneumatic confirmation of module status by monitoring pressure differentials within the sensing circuit.

3.7 Necessary tools

Tool	Size	Purpose
Hex screwdriver	2.5mm Hex	Installation / disassembly
Hex screwdriver	3mm Hex	Installation / disassembly
Torque wrench	4mm Hex	Installation / disassembly
Torque wrench	5mm Hex	Installation / disassembly

4 Transport and Storage

4.1 Inspection by recipient when taking possession

Upon arrival at the customer, installation clamping modules must be inspected for visible transportation damage.

- Report any defects or damage immediately to Vektek LLC and the carrier, who is liable for transportation damage.

NOTE

Any defects or damage must be claimed within 10 days of receipt of the product.

4.1.1 Unpacking



WARNING

Risk of injury caused by improper installation and disassembly of the mounting kit!

Non-observance can result in death or serious injuries!

- Observe the instructions attached to the installation clamping modules.
- Do not remove the mounting kit until the installation clamping module has been installed (see “5.3 Install the installation clamping modules”).
- Install the mounting kit before disassembling the installation clamping modules (see “5.4 Disassemble installation clamping modules”).

When unpacking the installation clamping modules, proceed as follows:

- Remove the packaging.
- Remove packaging materials, such as plastic film and tape, and dispose of properly.
- Do not throw away the original packaging. Keep it in case of return.
- Check the delivery for completeness based on your order.
- Always keep the provided documents; they contain important information on working with the installation clamping modules.
- Check the packaging contents for visible transportation damage.
- If you detect transportation damage or discrepancies between the packaging contents and your order, inform -Vektek LLC.

4.2 Supplied as standard

The installation clamping modules are supplied as standard with the following components:

- 1x Pre-installed clamping module
- 8x Cover caps
- 6x Cylinder screws
- 2x Threaded studs
- 1x O-rings
- 1x operating & installation manual

4.3 Intermediate storage

If the installation clamping modules are not installed immediately after delivery, they must be carefully stored in a protected location. The installation clamping modules must be temporarily stored in such a way that they are protected from cold, moisture, soiling, chemical and mechanical influences. You can obtain the recommended storage conditions of the installation clamping modules from chapter. The following points must be considered: Clean and then grease the surface of the installation clamping modules.



No liability is accepted for damage resulting from improper storage!

5 Installation

The installation clamping modules are pre-mounted by Vektex LLC. Safety is only guaranteed if the installation clamping modules are properly connected according to applicable safety regulations.

If several installation clamping modules are installed side by side, care must be taken that the height variation of the contact surfaces remains within 0.02 mm. The distance tolerances between the installation clamping modules must not exceed +/- 0.01 mm. The interchangeable pallet to be clamped with the integrated pull-studs must always rest completely on the contact surfaces of the installation clamping modules in the clamped state. To use the support control by means of dynamic pressure, the base plate of the interchangeable pallet must be even and polished (recommendation Rz3).



WARNING

Risk of injury caused by improper installation and disassembly of the mounting kit!

Non-observance can result in death or serious injuries!

- Observe the instructions attached to the installation clamping modules.
- Do not remove the mounting kit until the installation clamping module has been installed.
- Install the mounting kit before disassembling the installation clamping modules.

5.1 Ambient and Operating Conditions

Incorrect ambient conditions and operating conditions can cause the product to produce hazards that lead to serious injuries and considerable property damage and/or significantly reduce the service life of the product.

- Make sure that the installation clamping modules are sufficiently dimensioned according to the application.
- Make sure that the surfaces of the interface are always kept clean.
- Make sure that no chips of any kind reach the interface.
- Make sure that the installation clamping modules are used only within the defined usage parameters.
- Consider that corrosive, abrasive, and dusty environments (e.g. water, ozone, grinding dust) shorten the service life of the product.
- Check the resistance of the materials of the installation clamping module regarding the used or ambient media.

5.2 Preparatory measures

Before installation of the installation clamping modules, it must be ensured that

- connections for the compressed air supply are prepared,
- additional lighting equipment for installation is available,
- the mounting surface is clean and dust-free,
- tools required for the installation are at hand:
- Hexagon socket screwdriver and torque wrench.

5.3 Install the installation clamping modules

Installation step 1

- Deburr and clean the installation hole.
- Then lightly grease the installation hole. Use petroleum-based grease (non- silicone).
- Insert the installation clamping module into the installation hole without tilting it.

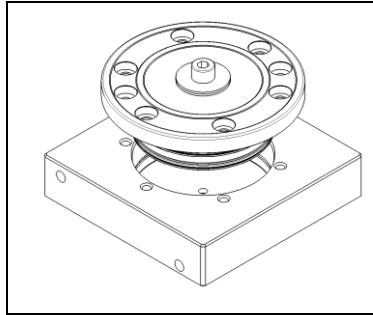

Illustration 9: Installation step 1

Installation step 2

- Screw in all cylinder screws (item 14) and tighten them crosswise to the corresponding tightening torque:
 - KP5.3: (M4) 2.9 Nm
 - KP10.3: (M6) 8.0 Nm
 - KP20.3: (M6) 15.0 Nm
- Make sure that the spring is pre-tensioned at installation.

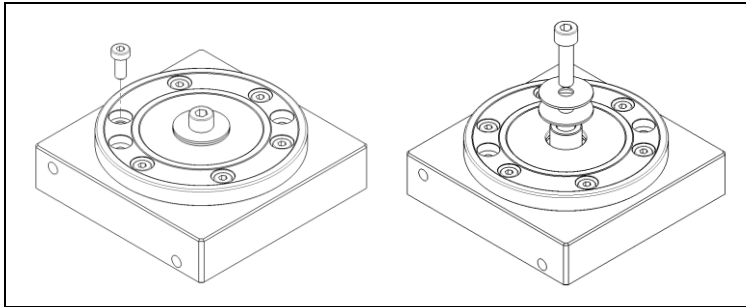

Illustration 10: Installation step 2 and step 3

Installation step 3

- Remove mounting kit and store for future possible disassembly.

Installation step 4

- Screw in the M6 threaded studs (item 15) with medium loctite.
- After contact with the fixture, loosen the threaded studs again by ¼ turn. Observe that the threaded studs are used for disassembly.

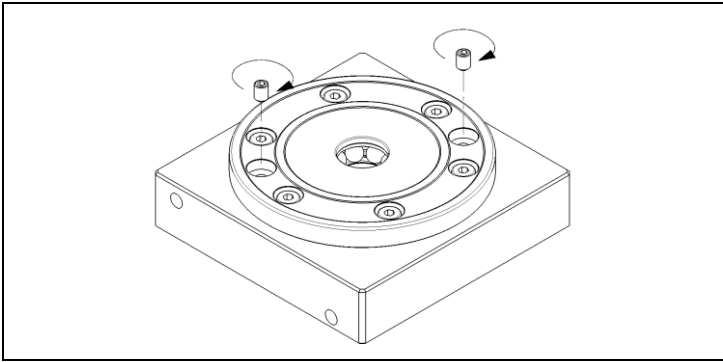

Illustration 11: Installation step 4

Installation step 5

- Note that 2 threaded studs (item 11 and 12) are supplied with the product.
- If the blow-out is used, install threaded stud with centric through-hole (item 11).
- If the blow-out is not used, install threaded stud without centric through-hole (item 12).

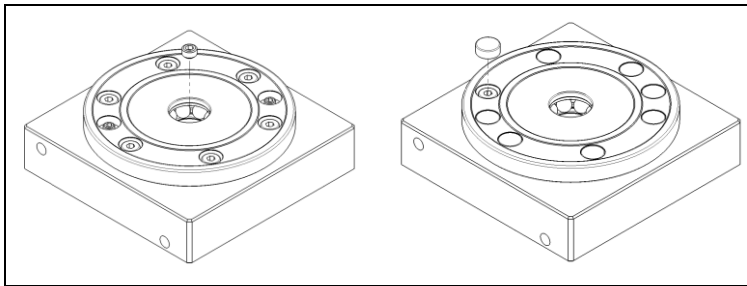

Illustration 12: Installation step 5 and step 6

Installation step 6

- Install the cover caps (item 18).

5.4 Disassemble installation clamping modules



WARNING

Danger of serious injuries due to improper removal from operation and disassembly!

Non-observance of the notes can result in damage, malfunctions or total breakdown of the installation clamping modules and impair their safety!

- Only qualified or instructed personnel may perform the work. Personnel must have practical experience with installation or disassembly.
- Have suitably qualified personnel disconnected energy supply lines.
- Before working, shut off pressure in the pneumatic system.
- When performing the work, wear safety clothing, safety shoes, protective gloves, and safety goggles.
- In case of doubt, contact Vektex LLC.

Disassembly step 1

- Remove the cover caps (item 18).

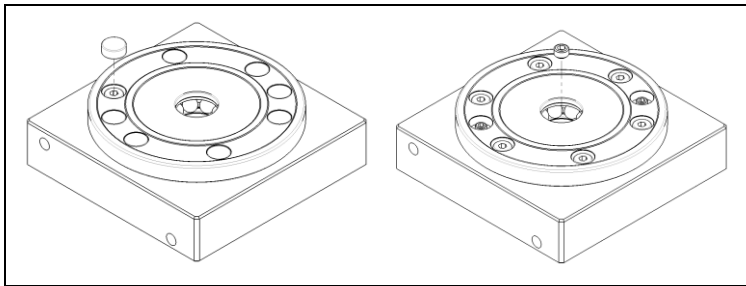

Illustration 13: Disassembly step 1 and step 2

Disassembly step 2

- Remove the centric threaded stud (item 11 / 12).

Disassembly step 3

- Install the mounting kit.

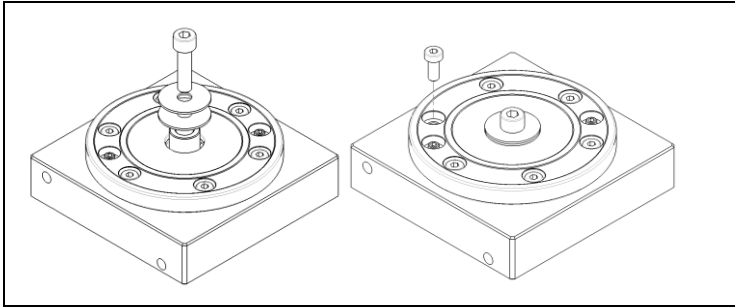

Illustration 14: Disassembly step 3 and step 4

Disassembly step 4

- Remove the cylinder screws (item 14).

Disassembly step 5

- Screw in the threaded studs (item 15) evenly. This raises the installation clamping module from the installation hole until it can be pulled out. Make sure that the installation clamping module is pulled out evenly and without tilting.

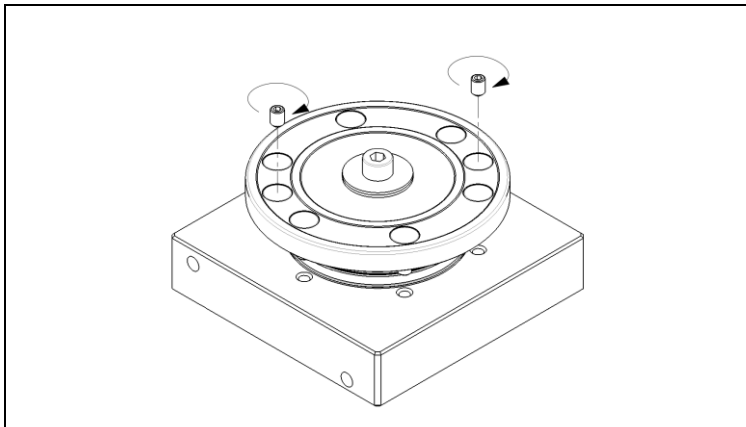

Illustration 15: Disassembly step 5

NOTE

Installation aid:

Screw in the installation kit, consisting of cylinder screw (item 13), installation sleeve (item 16) and disc (item 17) into the floor of the installation clamping module. In this way, the installation clamping module can be held together before removal so that it can be taken out as a unit.

Note that the feed bores for the pressure medium must be free during removal, as otherwise a vacuum could arise in the mounting bore.

6 Commissioning

Become adequately familiar with

- the equipment of the installation clamping modules,
- the mode of operation of the installation clamping modules,
- the immediate surroundings of the installation clamping modules,
- actions in an emergency.

Prior to initial commissioning or re-commissioning, carry out the following activities:

- Check the installation clamping modules for visible damage; immediately repair the defects found or report them to supervisory personnel - the installation clamping modules may only be operated in perfect condition.
- Check and make sure that only authorised persons are in the working area of the installation clamping modules and that no other persons can be endangered by engaging the clamping modules.
- Remove all objects and other materials from the work area that are not required for operation of the installation clamping modules.

7 Operation

7.1 Opening procedure

Pressurise the installation clamping modules. The installation clamping modules release the pull-stud, enabling it to be moved in and out of the system. The installation clamping modules will remain open as long as pressure is applied to the opening connection. The spring space must be capable of being completely vented during operation.

7.2 Clamping process

Switch off pressure to the installation clamping modules. The installation clamping modules interlock positively and are mechanically tensioned through spring force. The installation clamping modules will remain closed as long as no pressure is applied to the opening connection. The pressure line can be decoupled after the clamping operation - the installation clamping modules remain positively interlocked and self-locking. The spring space must be capable of being completely vented during operation.



CAUTION



During manual unloading and loading of the installation clamping modules, there is a risk of crushing limbs on moving parts and during the clamping operation!

Non-observance can result in minor injuries!

- Use a loading aid.
- Do not reach into the installation clamping module.

7.3 Integrated blow-out procedure

Air escapes from the installation clamping modules in the centre and serves to clean the interior space and contact surface. Chips or soiling can be removed through the integrated blow-out by providing connection 3 with compressed air.



CAUTION



During operation, there is risk of eye injury, since flying chips can arise from the automatic blow-out!

Non-observance can result in minor injuries!

- Wear safety goggles.

7.4 Manual blow-out process

The interior of the installation clamping modules can be blown out with an ordinary commercial compressed air blow gun or suctioned out with a vacuum device.

7.5 Clamp installation clamping modules

- The installation clamping modules are tensioned when delivered.
- After correct installation into a plate (see installation diagram), the installation clamping module can be opened through line 1.
- Due to the pressure reduction in line 1, the module is closed by the built-in springs.

8 Fault and repair measures

The information contained in this section supports the user in identification of malfunctions that can occur during operation of the system.

Fault	Cause	Repair measure
Clamping modules are leaking	Seals defective	Disassemble clamping modules, replace seals
Clamping modules do not open completely	Below minimum pressure	Check the operating pressure
	Operation without lubricated compressed air	Use maintenance unit with oiler
	Below minimum tubing diameter	Use correct tubing diameter (min. diameter 6 mm)
	Compressed air connections are not connected properly	Check compressed air supply
	Defect of a component due to overload	Replace clamping module or send it in

9 Maintenance

Appropriate maintenance is important for a long service life of the system and its components under proper functional and operating conditions, and it also guarantees the required operating safety over the long term.

9.1 Safety measures for maintenance work

Perform the specified maintenance work, such as cleaning, servicing, and inspections, when due. Before performing the maintenance work, observe the following points:

- Switch off pressure to the installation clamping modules.
- Secure the switched-off installation clamping modules against being switched on again unintentionally.
- Close off access to the work area of the installation clamping modules. Make sure that no unauthorised persons are in the working area of the installation clamping modules.
- Make sure that all module parts have cooled off to the ambient temperature.
- Immediately replace all imperfect module parts.
- All installation, operating, maintenance and cleaning personnel must observe the applicable accident prevention regulations in the country where the machine is installed.
- The installation clamping modules are constantly under high spring pressure. Due to the pre-tensioning of the spring stack, serious and even life-threatening injuries can result from improper maintenance.
- Wear safety shoes and all other required individual protective equipment as well as protective work clothing that covers the body as completely as possible.
- Do not wear any rings, watches, necklaces, bracelets, or loose clothing during maintenance work.
- To guarantee flawless functionality, only use original replacement parts.

After completion of the maintenance work and before using the installation clamping modules again, perform the following activities:

- Check all previously loosened screw connections again for firm seating.
- Check whether all previously removed components have been properly reinstalled.

9.2 Inspection and maintenance work

9.2.1 Maintenance intervals

Maintenance point	Maintenance work	See section
Daily		
Installation clamping modules	Cleaning	9.2.3.1
Monthly		
Installation clamping modules	Visual inspection	9.2.4.1
Installation clamping modules	Check fittings	9.2.4.2
Installation clamping modules	Check for deposits	9.2.4.3
Installation clamping modules	Check for leak tightness	9.2.4.4
Compressed air tubing or pipes	Check for leak tightness	9.2.4.5
Annually (but not later than after the specified clamping cycles)		
Installation clamping modules	Replace external O-rings	9.2.5.1

9.2.2 Preparatory measures

9.2.3 Maintenance – daily

9.2.3.1 Cleaning

Proceed as follows when cleaning the installation clamping modules:

- Check the inside of the installation clamping modules for dirt.
- Clean all module components thoroughly and remove contamination, dust, and foreign objects from the entire module area. General machine cleaning materials should be used for this. Never clean the installation clamping modules with high-pressure cleaners or degreasing cleaning materials.
- Do not use abrasive or corrosive materials for cleaning the installation clamping modules that may impair the legibility of the markings or type plates.

9.2.4 Maintenance – monthly

9.2.4.1 Visual inspection

- Visually inspect the condition of the installation clamping modules. When doing so, check the installation clamping modules for:
 - mechanical damage,
 - dirt deposits and
 - unusual noises.

9.2.4.2 Check fittings

- Check the fastening and catch screws for firm seating. Tighten loose fittings (screw tightening torque corresponding to the screw size and strength class).

9.2.4.3 Check installation clamping modules for deposits

- Check the installation clamping modules for deposits. Remove all deposits on the module surface.

9.2.4.4 Check installation clamping modules for leak tightness

- Check the installation clamping modules for leak tightness and function.

9.2.4.5 Check compressed air tubing or pipes for leak tightness

- Check the compressed air hoses or pipes of the installation clamping modules for leaks.

9.2.5 Maintenance – annual

Annual maintenance, but not later than after the following cycles:

Module	Clamping cycles
570258	4,000,000
570259	4,000,000

9.2.5.1 Replace external O-rings

When replacing the outer O-rings, proceed as follows:

- Replace all outer O-rings (sealing kit available from Vekttek LLC).
- Lightly grease the O-rings of the installation clamping module.

Module	Seal Kit
570258	60570258
570259	60570259